



10BASE-T1L Switch

Quick Installation Guide

Features

- 10BASE-T1L IEEE Standard 802.3cg-2019 compliant Class 12
- DIN-rail mounting
- Output Power Rating 13.2 W
- Transmitting Ethernet signals and power over a single twisted pair of cables. This eliminates the need for complex and costly cabling infrastructure.
- 10 Mbps full-duplex communications up to 1,000 meters over a single pair of twisted wires.
- Use in settings with limited power resources due to its low power requirements.

Applications

- Factory automation
- Edge sensors and actuators
- Building automation and fire safety
- Condition monitoring and machine connectivity

Overview

The NE-T1L-PSE plays the role of PSE, and insert the data signal and power signal that are transmitted to the PD. The NE-T1L-PSE plays a dual role of providing power to industrial devices, and enabling Ethernet connections. The NE-T1L-PSE has a wide operating temperature range of -40 to 75°C, and are designed to withstand a high degree of vibration and shock. The rugged hardware design makes the NE-T1L-PSE perfect for ensuring that your Ethernet equipment can operate in critical industrial environments, such as in hazardous locations, and complies with FCC and CE standards.

NOTE

Throughout this Hardware Installation Guide, we use SPL as an abbreviation for 10BASE-T1L Splitter , and we use PSE as an abbreviation for 10BASE-T1L Switch , and we use MC as an abbreviation for 10BASE-T1L Media Converter :

SPL = 10BASE-T1L Splitter (NE-T1L-SPL)

PSE = 10BASE-T1L Switch(NE-T1L-PSE)

MC = 10BASE-T1L Media Converter(NE-T1L-MC)

Package Checklist

The NE-T1L-PSE is shipped with the following items. If any of these items is missing or damaged, please contact your customer service representative for assistance.

- 10BASE-T1L Switch(NE-T1L-PSE)
- Quick installation guide (printed)
- Warranty card

Dimension : (mm)

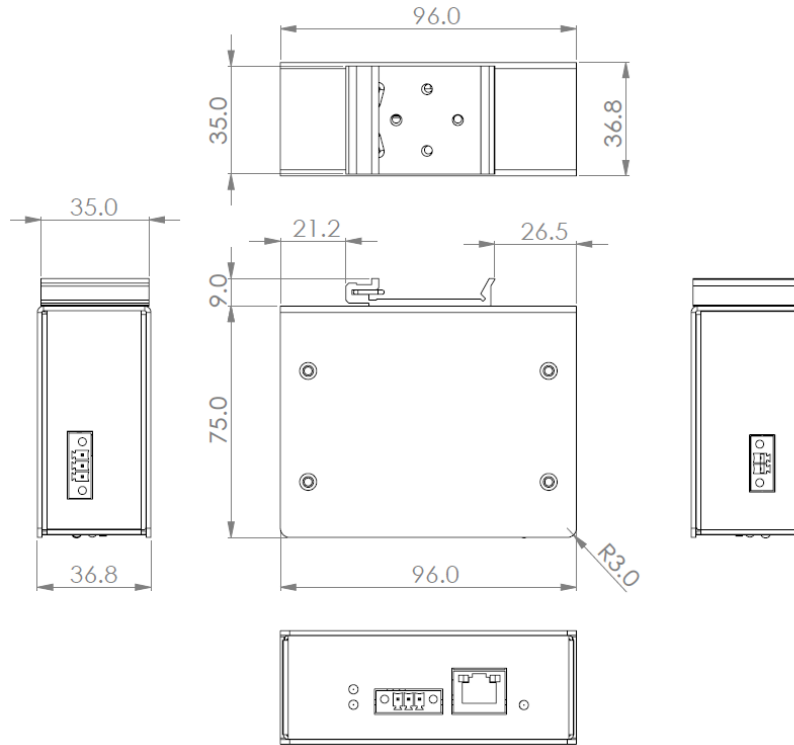

Panel Layout :

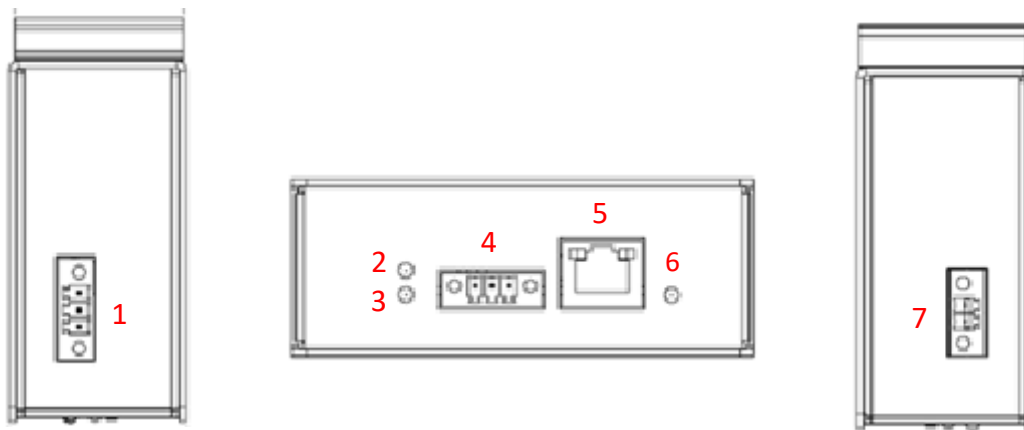

- | | |
|--|---------------------------------------|
| 1. DC IN Connector (Only NE-T1L-MC & NE-T1L-PSE) | 5. 10-Base-T Connector(RJ45) |
| 2. Act LED | 6. Power LED |
| 3. Link LED | 7. DC Out Connector (Only NE-T1L-SPL) |
| 4. T1L Connector | |

DIN-rail Mounting

The plastic DIN-Rail attachment plate should already be fixed to the back panel of NE-T1L-PSE when you take it out of the box.

If you need to reattach the DIN-Rail attachment plate, make sure the stiff metal spring is situated towards the top, as shown in the figures below.

STEP 1:

Insert the top of the DIN-Rail into the slot.

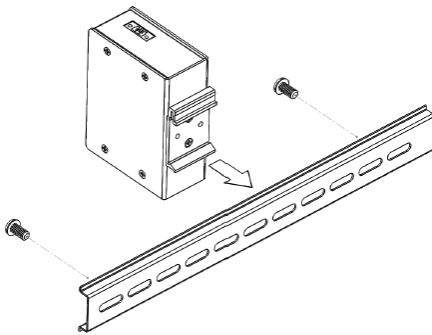

STEP 2:

The DIN-Rail attachment unit will snap into place as shown below.

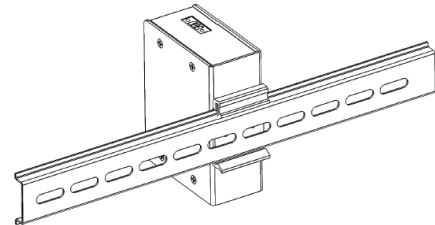

To remove the NE-T1L-PSE from the DIN-Rail, insert a flat-blade screw driver horizontally into the DIN-Rail kit under the NE-T1L-PSE, and then pull it upwards and release NE-T1L-PSE towards you away from the DINRail.

Grounding the NE-T1L-PSE

Grounding and wire routing help limit the effects of noise due to electromagnetic interference (EMI). Run the right most contact of the 3-contact terminal block to the grounding surface prior to connecting devices.

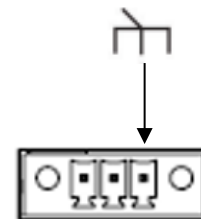

ATTENTION

This product is intended to be mounted to a well-grounded mounting surface, such as a metal panel.

Wiring Requirements



Do not disconnect modules or wires unless the power supply has been switched off or the area is known to be nonhazardous. The devices may only be connected to the supply voltage shown on the type plate. The devices are designed for operation with a Safety Extra-Low Voltage. Thus, they may only be connected to the supply voltage connections and to the signal contact with the Safety Extra-Low Voltages (SELV) in compliance with IEC 60950-1/EN 60950-1.



This unit is a built-in type. When the unit is installed in another piece of equipment, the equipment enclosing the unit must comply with fire enclosure regulation IEC 60950-1/EN60950-1 (or similar regulation).



Safety First!

Be sure to disconnect the power cord before installing and/or wiring your device. Calculate the maximum possible current in each power wire and common wire. Observe all electrical codes dictating the maximum current allowable for each wire size. If the current goes above the maximum ratings, the wiring could overheat, causing serious damage to your equipment.

You should also pay attention to the following items :

- Use separate paths to route wiring for power and devices. If power wiring and device wiring paths must cross, make sure the wires are perpendicular at the intersection point.

NOTE : Do not run signal or communications wiring and power wiring in the same wire conduit. To avoid interference, wires with different signal characteristics should be routed separately.

- You can use the type of signal transmitted through a wire to determine which wires should be kept separate. The rule of thumb is that wiring that shares similar electrical characteristics can be bundled together.
- Keep the input wiring and the output wiring separated.
- It is strongly advised that you label the wiring to all devices in the system when necessary.

Specifications

Ethernet Interface	10BASE-T Ports(RJ45 connector)	1 Full/Half duplex mode Auto MDI/MDI-X connection Auto negotiation speed
	PoDL Ports(PD), 10BASE-T1L	1 Single Pair Auto negotiation speed 10BASE-T1L Class 12
	Standards	IEEE 802.3cg for PoDL Class12
Power Parameters	Operating Input Voltage	20 ~ 27VDC
	PoDL Power Rating	13.2W
	Overload Current Protection	Supported
Physical Characteristics	Dimensions	W 96x D 75x H 36.8(mm)
	Installation	DIN-rail mounting
	IP Rating	IP30
	Weight	390g
Environmental Limits	Operating Temperature	-20 to 60°C
	Storage Temperature (package included)	-40 to 75°C
	Ambient Relative Humidity	5 to 95% (non-condensing)
Standards and Certifications	EMS	EN61000-4-2 (ESD), Contact: 6 kV; EN61000-4-3 (RS), 80~1000Mhz, 3V/m EN61000-4-4 (EFT),Signal: 0.5 kV EN61000-4-5 (Surge),Signal:0.5kV
	EMI	FCC Part 15 Class A, EN 55032 Class A